

1000 Volt IGBT Driver Board

Preliminary

Features

- 1000 Volts maximum input
- 800 amp maximum peak pulse current
- Pulse width range: 50 μ s. to 1ms.
- Pulse rise time: 10 μ s.
- Over voltage, over temp. & input protection

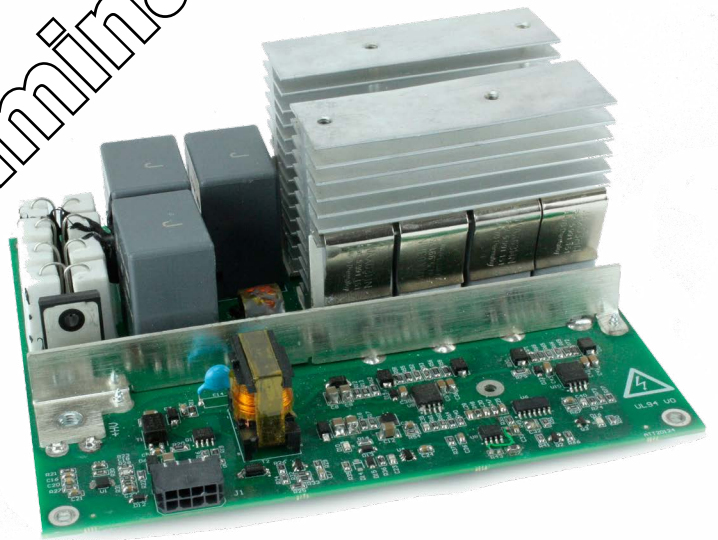

Applications

- Aesthetic and surgical laser systems
- Intense pulsed light devices
- Flashlamp pumped lasers
- UV curing systems
- Sterilization systems

The 1000 volt IGBT Driver Board is designed for partial discharge applications in laser, intense pulsed light devices and many other high voltage discharge applications. The board combines high peak current capacity with a wide range of pulse widths in a compact, low cost device.

This board can be combined with any of the LCH series capacitor charging power supplies and the A-SIM-30-12, 30 watt flashlamp simmer for a complete easy to implement system.

Input High Voltage vs. Pulse Width

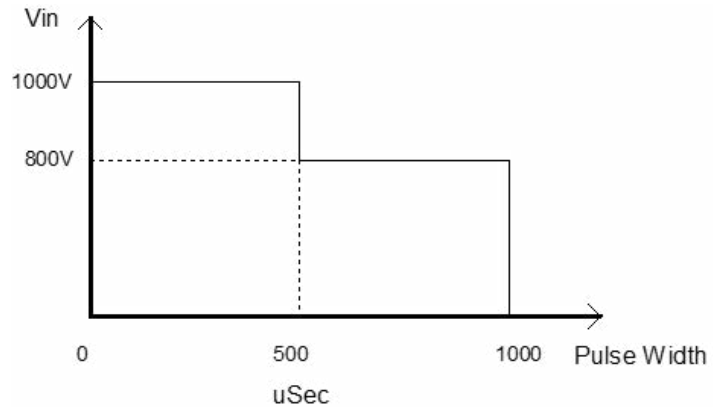

Typical System Block Diagram

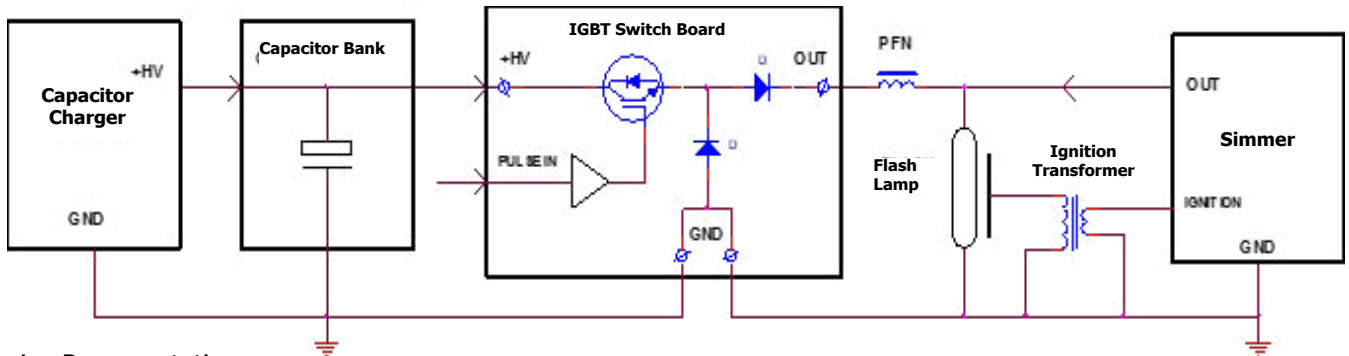

Exclusive Representation:

NEW SOURCE TECHNOLOGY LLC

6678 Owens Drive, Suite 105, Pleasanton, CA 94588
 Phone: +1 (925) 462-6888 | Fax: +1 (925) 462-8388
 newsourcetechology.com | sales@newsourcetechology.com



Creative Technology Solutions

Specifications

Maximum operating input voltage	1000V for pulse width < 0.5mSec, 800V for pulse width < 1mSec
Maximum pulse peak current.	800A
Maximum rise / fall time	10uS @ 800A with 1,000V operating voltage
Output current pulse width range	50µs to 1ms.
Input command pulse signal	TTL 3.3V, 5V (input isolated from high voltage power and AUX. 24V).
Pulse signal range	50uSec to 1mSec
Auxiliary input power	24VDC (20 to 32V) / 0.5A
Function	IGBT Board Shut down by short connection pin 3 to pin 4 of J1.
Indications	Green LED Aux. power ON, Red LED – Fault indication.
Protection:	
Over Load Protection	Output pulse current over 850A ± 5% - Output shut down. Recovery after aux. voltage re-power.
Over Temperature Protection (option)	IGBT heat sink over 70°C – driver shut down. Automatic recovery after the temperature drops below < 40°C
Aux power protection	Aux power under voltage protection: V start > 18VDC. Aux power voltage reverse polarity protection.
Withstand Voltage	IN / OUT signals to Aux. power – 1kVrms. IN / OUT signals to HV / GND – 2kVrms
Connectors:	
Interface and AUX power (Conn. J1)	Wire housings receptacle 8 pin dual row connector P/N: 430250800 Molex. Wire terminals P/N: 430300001.
Power	+HV, OUT, GND – Terminal block screw M5.
Environment:	
Operating Ambient Temperature	0°C to +40°C
Storage Temperature	-20°C to +80°C
Cooling	Open frame, can be cooled by a user installed fan (fan not included)
Humidity	10% to 90% RH non-condensing
Mechanical:	
Dimension L x W x H	160 x 140 x 62 mm
Weight	TBD

Connector J1 Pin assignment

Pin #	Function:	Description:
1	Signals GND	Common terminal for TTL, IN and OUT signals.
3	Shut Down	IGBT Board shut down. ON - pin floating. OFF – short to pin 4.
4	PWR RTN	24V Aux. power negative terminal.
5	Pulse	Input PWM control pulse. Type: TTL 3.3V, 5V Active – HI.
6	Fault	Output Fault Signal. Type: open collector without pullup resistor. Active – HI.
2, 7	N.C.	Not connected
8	PWR	+24V Aux. power positive terminal.

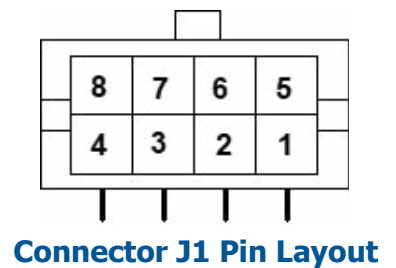

Exclusive Representation:

NEW SOURCE TECHNOLOGY LLC

6678 Owens Drive, Suite 105, Pleasanton, CA 94588
 Phone: +1 (925) 462-6888 | Fax: +1 (925) 462-8388
 newsourcecetechnology.com | sales@newsourcecetechnology.com

Outline Drawing

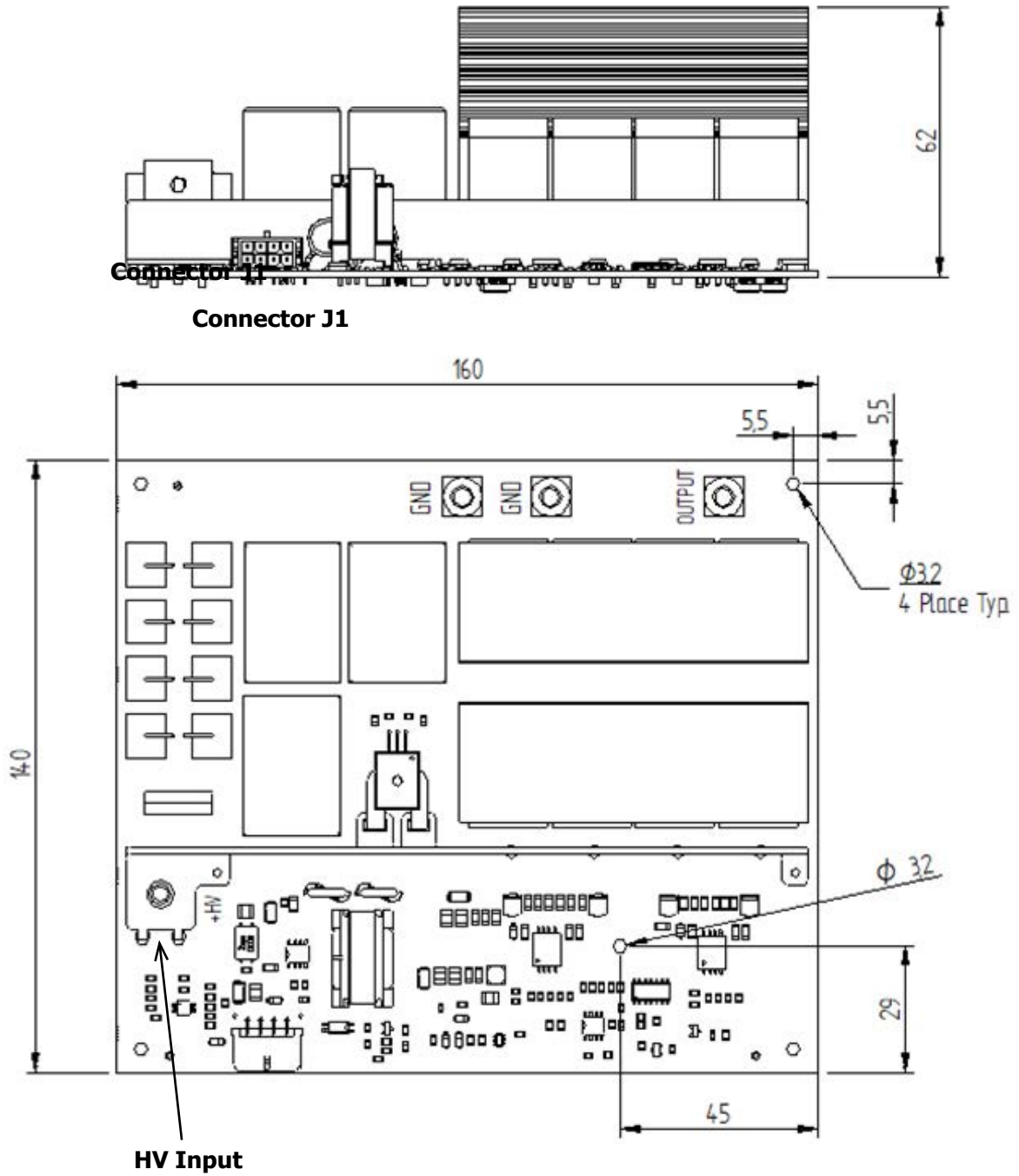

Exclusive Representation:

NEW SOURCE
TECHNOLOGY LLC

6678 Owens Drive, Suite 105, Pleasanton, CA 94588
Phone: +1 (925) 462-6888 | Fax: +1 (925) 462-8388
newsourcetechology.com | sales@newsourcetechology.com

3

 **ADVICE**

Creative Technology Solutions