

A-SIM-30-12 Simmer Power Supply



Design incorporates features that enhance performance and interface versatility in a small low-cost package.

The A-SIM-30-12 flashlamp simmer is designed for the OEM customer. Simmers are a vital part of lamp-based laser or IPL systems and are used to maintain a constant current flow through the lamp between discharges.

With a maximum output of 150mA and 1200 volts open circuit combined with an automatic trigger pulse the A-SIM-30-12 is ideal for simmering lamps in aesthetic and surgical devices.

Innovative features of the A-SIM-30-12 simmer include a wide range of input voltages, convenient "power" and "lamp on" LEDs, protection from transient voltage and a readily available, convenient variety of user interface configurations.

Factory preset options include output current limits and post trigger current boost. Mating connector supplied with simmer.

Features

- 30 watts output
- 150mA. maximum output current
- 1200V open circuit voltage
- Post trigger current boost
- Input: 24VDC Nominal (20VDC to 32VDC)
- 2000V transient voltage immunity
- Power "ON" & "LAMP ON" LED's
- Convenient "lamp on" indication signal
- Wide range "Enable" input (4.5V to 24V)
- Floating & non-floating "Enable"
- Positive or Negative logic "Enable"

Applications

- Aesthetic and surgical laser systems
- Intense pulsed light devices
- Flashlamp pumped lasers
- UV curing systems
- Sterilization systems

Exclusive Representation:

**NEW SOURCE
TECHNOLOGY_{LLC}**

6678 Owens Drive, Suite 105, Pleasanton, CA 94588
Phone: +1 (925) 462-6888 | Fax: +1 (925) 462-8388
newsourcetechology.com | sales@newsourcetechology.com

1

 **ADVICE**

Creative Technology Solutions

Specifications

Input/ Output	
Input supply voltage range	24V nominal, minimum 20VDC, maximum 32VDC
Maximum input current	2A@20V, 1.7A@24V
Output current	150mA standard. (100mA to 150mA Max. optional)
Current boost following flash option	450mA for at least 3mS standard. (no boost optional)
Max. average output power	30W
No load voltage	1,200V ± 60V
Maximum external transient peak voltage at the output	2,000V, which may be induced by external circuitry
Efficiency	75% typical including internal ballast
Ignition trigger voltage driving ignition transformer	300V
Ignition trigger pulse energy	20mJ.
Ignition trigger repetition rate until flash lamp is ignited	Approx. 10Hz to 20Hz (ignition trigger pulse every 50mS to 100mS)
Environment	
Operating Ambient Temperature	0°C to +50°C
Storage Temperature	-20°C to +80°C
Cooling	Cooled by free air convection
Humidity	10% to 90% RH non-condensing
User interface	
Enable signal voltage levels (Ven)	Disabled: 0V < Ven < 0.4V or open, Enabled: 4.5 < Ven < 24V
Green LED lamp "Enable ON" indication.	Light with Enable signal is ON.
Red LED lamp "Lamp ON" indication.	Light when the lamp is ON with simmer current
"Lamp ON" signal	Open drain, pulls to 0V when the lamp is ON with simmer current
Green LED	Power ON
Red LED	Lamp ON
Mechanical Dimensions	
Size L x W x H in mm (Inches)	154 x 66.5 x 37.2mm (6.0" x 2.6" x 1.5")
Weight	310gr (10.9 oz.)
Insulation, input power and output to chassis	1500Vrms
Insulation, control signal to chassis & input power	1500Vrms
Insulation, control signal to input power & output	1500Vrms

- Lower currents can be ordered (factory pre-set calibration)
- Can be modified upon customer request (voltage, current etc.)

Exclusive Representation:

NEW SOURCE
TECHNOLOGY_{LLC}

6678 Owens Drive, Suite 105, Pleasanton, CA 94588
Phone: +1 (925) 462-6888 | Fax: +1 (925) 462-8388
newsourcetechology.com | sales@newsourcetechology.com

2



Creative Technology Solutions

Interface and Control Options

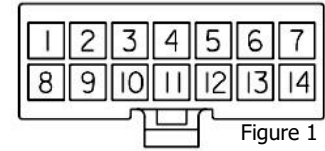

Figure 1

Pin #	Pin Name	Description
Pin 2	Ignition trigger output	Drive for external ignition transformer
Pin 4	External Power input (+)	External Power input, nominal +24V (20V<Vin<32V)
Pin 5	External Power input return	GND (pins 5 and 12 are internally shorted)
Pin 7	Enable command signal input	Please refer to the figures below for diverse options
Pin 8	High Voltage output (+)	Simmer output, connected to lamp
Pin 10	Lamp ON signal	Open collector "Lamp ON" signal. Active = LOW
Pin 11	Aux output	Please refer to the figures below for diverse options
Pin 12	Simmer output return	GND (pins 5 and 12 are internally shorted)
Pin 14	Enable command signal return	Please refer to the figures below for diverse options
Pin 1,3,6,9	No connection	

Figure 1: View from wire entry side. Molex, P.N. 0039012140, contacts: 0039000038. Mating connector supplied.
Mating Connector: (QTY1) Molex P.N: 0039012140. Contacts: (QTY14) Molex P.N: 0039000038, suitable for wires AWG18 to AWG24

Simmer Control (Enable) Options

Floating External Gate Control
Active High

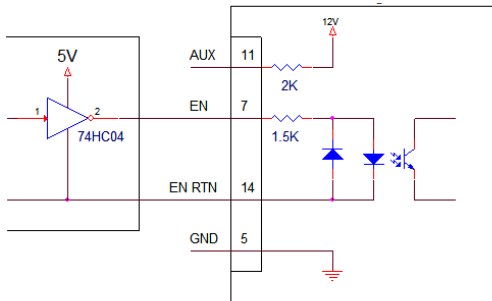

Floating External Gate Control
Active Low

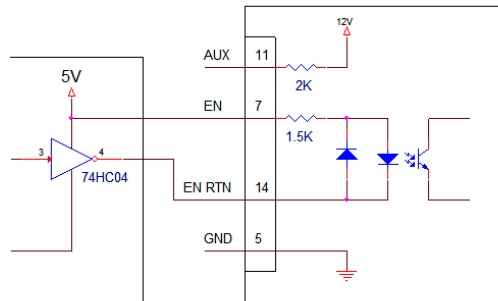

Floating Voltage Control
Active High

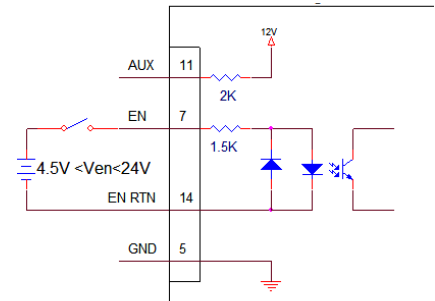

Open Collector or Dry Contact
Active Low

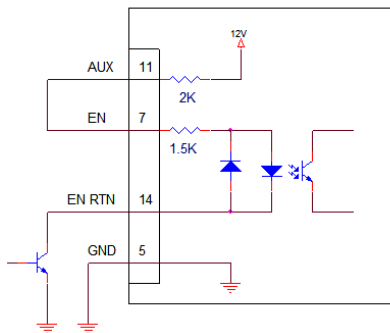

Open Collector or Dry Contact
Active High

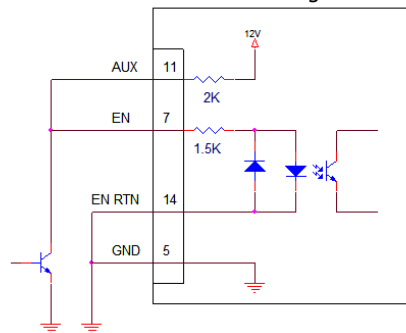

Simmer Always ON

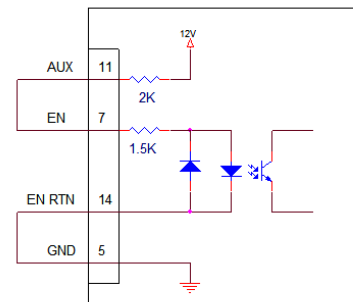

Exclusive Representation:

NEW SOURCE TECHNOLOGY LLC

6678 Owens Drive, Suite 105, Pleasanton, CA 94588
Phone: +1 (925) 462-6888 | Fax: +1 (925) 462-8388
newsourcetechology.com | sales@newsourcetechology.com

Simmer Connection Diagram

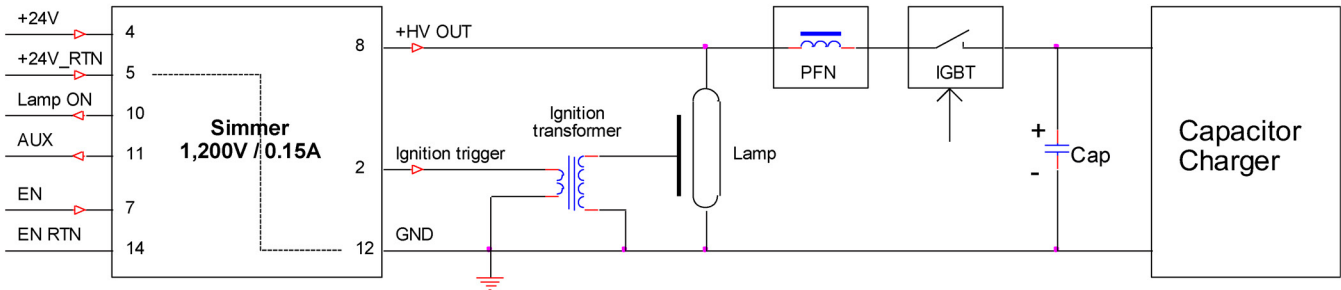

Outline Drawing

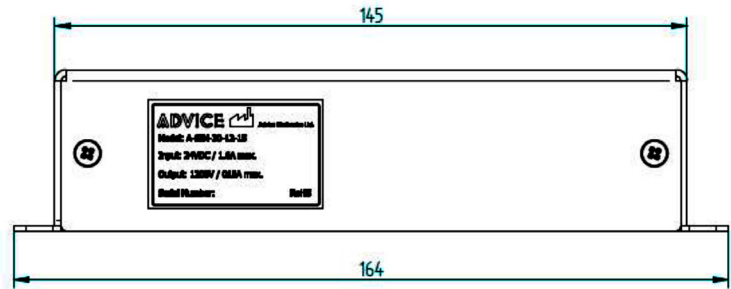
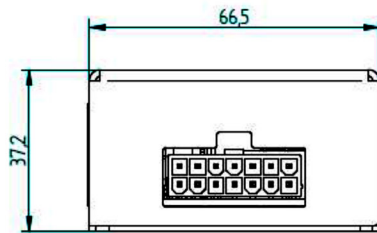

Part Number Selection Guide

The part number includes the following options:

Simmer output current can be calibrated by the customer. Factory pre-set current values are available between 100mA and 150mA. Enter the two most significant digits (12 = 120mA.) to indicate the desired pre-set current. Omit for the standard 150mA version.

Current boost following flash: enter "B" for boost, and "N" for no-boost.

Examples:

A-SIM-30-12-10-B for a 100mA simmer, with current boost following flash

A-SIM-30-12-N for a 150mA simmer, without current boost following flash

A-SIM-30-12-B for a 150mA simmer, with current boost following flash

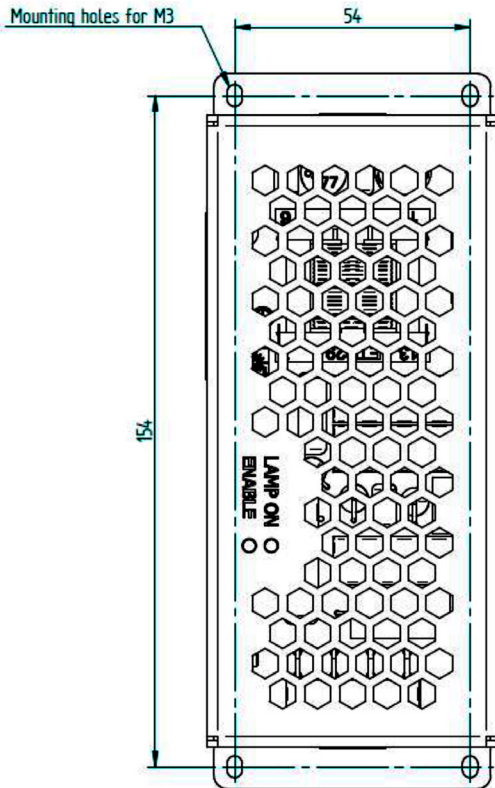

Visit the New Source Technology website to see the complete Line of capacitor charging power supplies from 500 to 9000watts.



Exclusive Representation:

NEW SOURCE TECHNOLOGY LLC

6678 Owens Drive, Suite 105, Pleasanton, CA 94588
 Phone: +1 (925) 462-6888 | Fax: +1 (925) 462-8388
 newsourcecetechnology.com | sales@newsourcecetechnology.com